

VECTOR 500/1100 OFF ROAD with Powered Rotation

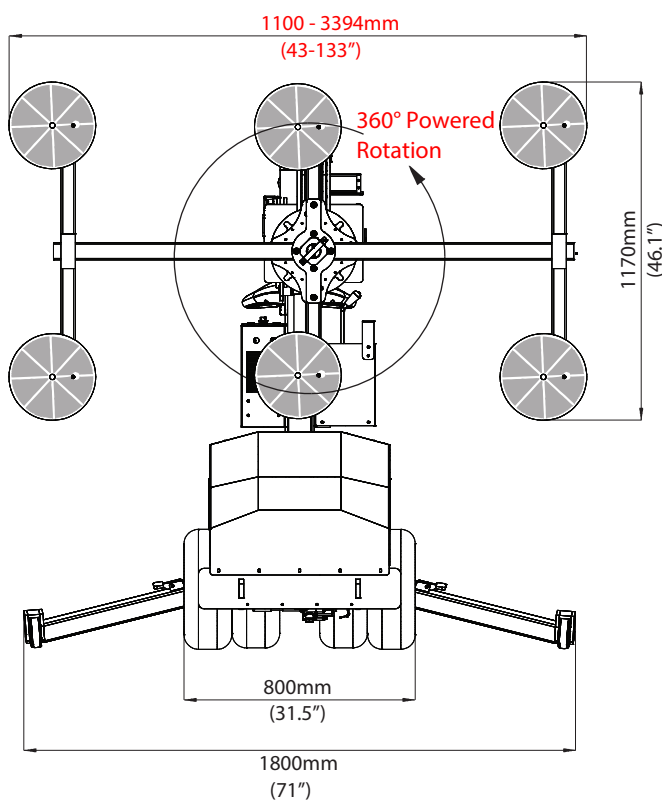
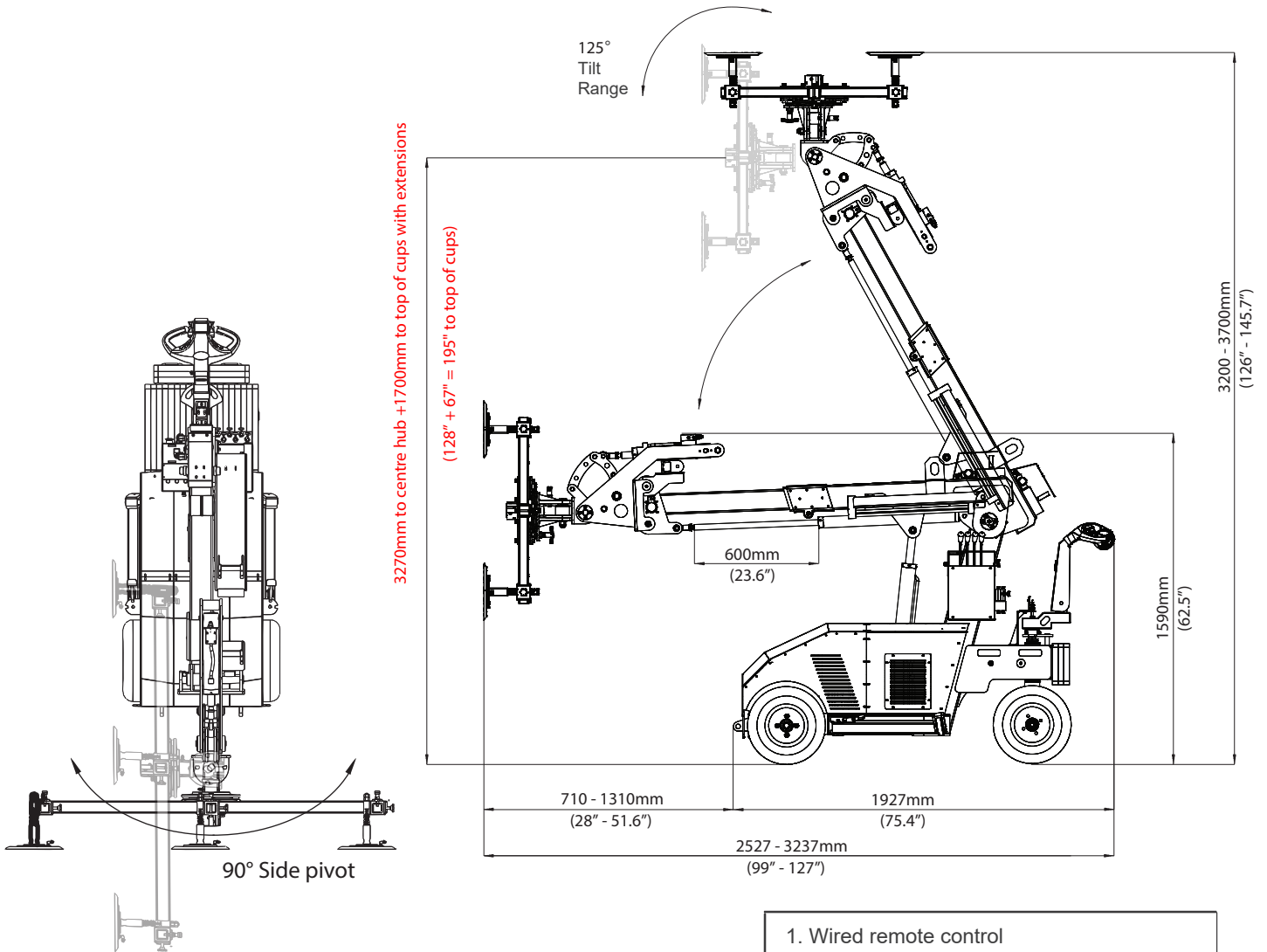

1. Wired remote control
2. Capacity: 500kg (1100lbs)
3. Variable speed control hydraulic system
4. Overload sensor alarm
5. Hydraulic System: 24v / 1300watts
6. 4 x 400mm (16") Front & Rear Wheel
7. Battery: 2 x 12v / 120A Deep Cycle
8. Charger: 110 - 220v
9. Dual Vacuum Pumps: 2 x 24V
10. Vacuum Cups: 6 x 300 mm (12") sprung
11. Vac Cup Area Height: 1170 mm (46")
12. Vac Cup Width: 1100-3394 mm (43-133")
13. Front Wheel Drive
14. No-Load Climbing: 15% Gradient
15. Machine Weight: 679kg (1500 lbs) Counterweights: 336kg (740 lbs)
16. SIDE SHIFT - 125 mm (5")
17. Powered rotation: 360°