

BSV-45NK

Automatic bending machine for all conventional, synthetic and composite spacer types

LiSEC

CREATING VISIONS. PROVIDING SOLUTIONS.



The BSV-45NK is a fully automatic spacer profile bending machine for processing all conventional, synthetic and composite spacer frames for the production of insulating glass.

The system is equipped as a standard for processing aluminium, steel, stainless steel, synthetic and composite profiles. The profile magazine can be equipped with 4, 6, 8 and 15 profile storage slots. The profile magazine is filled manually by sliding the profiles into the individual slots from the support surface.

Fully automatic profile transport, cutting and bending. With the new saw unit, it is possible to cut aluminium, steel, stainless steel, synthetic profiles and in particular composite profiles with just one saw blade. Profile types, order data, the geometry and the desired split can be selected or also entered via an easy-to-use control panel. Optionally, the machine control system can be monitored by remote control as well as by online data transfer.

For you, this means:

- Processing of aluminium, steel, stainless steel, synthetic and composite profiles
- 4, 6, 8 or 15-slot profile magazine
- One saw blade for cutting all profiles types
- Shape capability according to the LiSEC shape catalogue
- High accuracy thanks to the precision-guided profile transport
- Easy operation via touchscreen
- Swisspacers can also be processed
- Automatically adjustable bending die for aluminium, synthetic and Swisspacer profiles



The extended lever supports the frames during the bending process

Technical data

and models

LiSEC

CREATING VISIONS. PROVIDING SOLUTIONS.

Profile height	6 - 8,5 mm
Profile types	aluminum, steel, stainless steel, plastic
Profile width	6 - 24 mm adjustable in increments (aluminum, steel, stainless steel) 8 - 24 mm adjustable in increments (plastic) optional 8 - 24 mm adjustable in increments (Swisspacer)
Profile magazine	4-slot
Minimal size	250 x 100 mm
Maximal size	6.600 x 3.300 mm

Optional

Profile magazine versions

- 6, 8 or 15-slot profile storage magazine with separation device

Profile magazine extensions

- 4, 6 or 8-slot profile storage magazine with a loading depth of 500mm (standard: 350mm)
- Profile magazine with automatic profile change unit
- Drilling station designed to drill holes for manual gas filling and for inserting Georgian bars/muntins (BM-45HM)

Function extensions (software)

- Shapes according to the LiSEC shape catalogue
- Bending of ‚free shapes‘
- Creation of transfer files for non-LiSEC software
- Corner connection (3 corners are bent, the 4th corner is connected using a corner connector)
- Minimal radius R = 50 - 100mm (aluminium, steel)
- Minimal frames down to 190 x 50mm (aluminium, steel)

Bending tools

- Automatic bending die for aluminium (8 - 24mm)
- Automatic bending die for plastic (10 - 24mm)
- Automatic bending die for Swisspacer (10 - 24mm)
- Standard bending die, or bending die for processing minimal frames or minimal radii

Material-related extensions

- Processing of Swisspacer

General options

- Larger table top for processing unsplit frames sized up to 2700 x 1300mm and frames sized up to 4900 x 2700mm, split into two U or L shapes
- Frame connecting device for longitudinal connectors used on the 4th side

Printer options

- Printer control for inkjet printers
- Multiple frame labelling

BSV-45NK

Models

LISEC

CREATING VISIONS. PROVIDING SOLUTIONS.

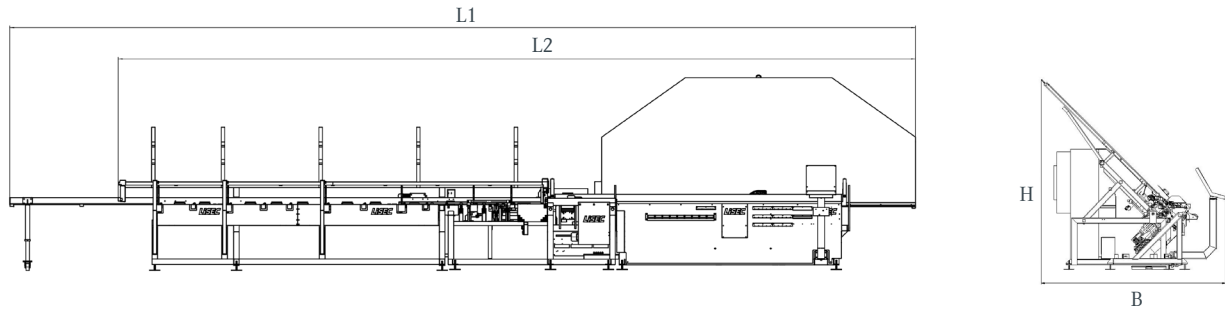

	L1 (mm)	L2 (mm)	B (mm)	H (mm)	Power consumption (kW)	Operating air pressure (bar)	Air consumption (l/min)
BSV-45NK	12980	11430	2650	2750	1,33	6	25